

YOUNG LIVES SECONDARY SCHOOL SURVEY

Maths | Wave 2

This test booklet contains mathematics items administered to students in Grades 10, at Wave 2 of Young Lives' school survey in Vietnam. This survey took place in 2017.

Items were selected following extensive piloting.

For more details on item sources and the test development process, see (Iyer et al, 2017. Young Lives School Survey, 2016–17: Evidence from Vietnam). Some items in this test are copyright Educational Initiatives, Ahmedabad, India. For permission to use these items, please contact info@ei-india.com.

YOUNG LIVES SECONDARY SCHOOL SURVEY

Maths | Wave 2

You should have been given 2 documents: this **Test Booklet** and a separate **Answer Sheet**. Before you begin, read these instructions carefully.

Carefully read the questions in this **Test Booklet**. For each question, there are four options – A, B, C and D. Only one of these options is correct. Identify the option which you think best answers each question.

On the **Answer Sheet** given to you, find the corresponding question number and draw a cross ('X') on the option you want to select. Only select one option for each question.

Example

| | | | |
|---|---|---|---|
| A | B | X | D |
|---|---|---|---|

Please do not write on the Test Booklet. Use a separate piece of paper for any working out.

If you want to change your answer, blacken the entire square for your original answer and then write a cross ('X') on the new answer you want to select.

Example

| | | | |
|---|---|---|---|
| X | B | C | D |
|---|---|---|---|

Each question carries one mark. No marks will be deducted for wrong answers.

1

The table below shows the relationship between x and y .

| | | | | |
|-----|---|---|----|----|
| x | 2 | 3 | 4 | 5 |
| y | 4 | 7 | 10 | 13 |

Which of these equations expresses this relation?

A. $y = 2x + 2$

B. $y = x + 2$

C. $y = 4x - 4$

D. $y = 3x - 2$

2

Δ is a common factor of 3 numbers X , Y and Z .

Shown below are the prime factorizations of X , Y and Z .

$$X = 2 \times 3 \times 5 \times \Delta$$

$$Y = 2 \times 2 \times 3 \times 3 \times 5 \times \Delta$$

$$Z = 2 \times 2 \times 2 \times 3 \times 3 \times \Delta$$

Which of the following is DEFINITELY a factor of the sum $X + Y + Z$?

A. 4**B.** 5**C.** 6**D.** 9**3**

Mai takes tablet A every 4 hours and tablet B every 6 hours. How often will she take both the medicines at the same time?

A. Every 2 hours**B.** Every 10 hours**C.** Every 12 hours**D.** Every 16 hours

4 Numbers that can be written in the form $\frac{m}{n}$ where m and n are integers and n is not equal to 0 are called rational numbers.

Which of the numbers in the list below are rational numbers?

| | | | |
|-----------------|-----------------------|-------------------|---|
| $-\frac{25}{2}$ | 0.3333... (recurring) | $\frac{0.33}{10}$ | 1 |
|-----------------|-----------------------|-------------------|---|

- A. Only $-\frac{25}{2}$ and 1
- B. Only $-\frac{25}{2}$ and $\frac{0.33}{10}$
- C. Only $-\frac{25}{2}$, 0,3333... (recurring) and 1
- D. All of them are rational numbers

5 $-4 - (-5) = \underline{\hspace{2cm}}$

- A. -1
- B. 1
- C. -9
- D. 9

6 Which of these numbers are equal?

1^{119} 119^1 119^0 1^1

- A. Only 1^{119} and 1^1
- B. Only 1^{119} and 119^1
- C. Only 1^{119} , 119^0 and 1^1
- D. None of them are equal

7 If  represents 75%, which of the following represents 125%?

- A. 
- B. 
- C. 
- D. 

8

What fraction of the shape below is shaded?

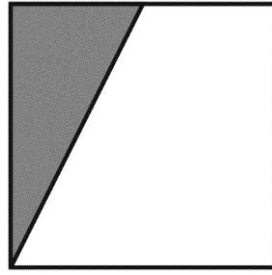
**A.** 1**B.** $\frac{1}{2}$ **C.** More than $\frac{1}{2}$ **D.** Less than $\frac{1}{2}$ **9**

0.5 is the same as:

i) **5% of 10**ii) **10% of 5**iii) **50% of 1****A.** Only (i)**B.** Only (ii)**C.** Both (i) and (ii)**D.** All - (i), (ii) and (iii)**10**

3 of the different faces of a cuboidal box have surface areas 20 cm^2 , 48 cm^2 , and 60 cm^2 respectively.

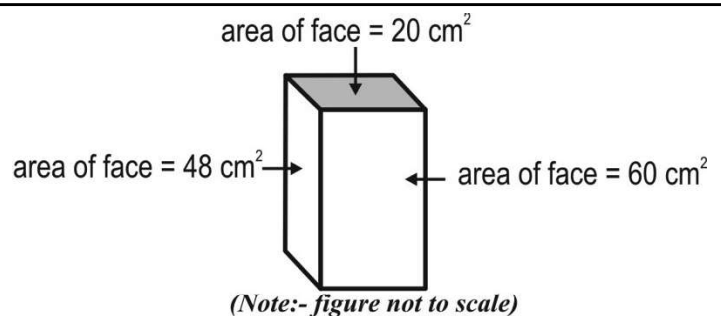

What is the volume of the cuboidal box?

A. 128 cm^3 **B.** 240 cm^3 **C.** 256 cm^3 **D.** 57600 cm^3

11 What will happen to the perimeter of the larger square if the shaded part is cut out of it?

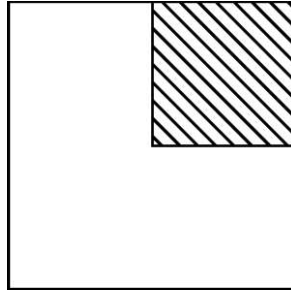

- A. It will increase
- B. It will reduce
- C. It will stay the same
- D. It depends on the size of the square

12 Shown here is a triangle with two of its sides as 9 cm and 4 cm and a square of side 5 cm.

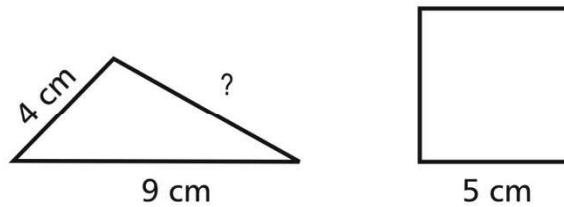

Both the figures have the same perimeter. What would be the length of the third side of the triangle?

- A. 5 cm
- B. 7 cm
- C. 8 cm
- D. 13 cm

13 Lines l and m are parallel. Which figure shows the correct angle measurement?

- A.
- B.
- C.
- D.

-
- 14** Giang draws a triangle whose three sides are of length 5 cm each. He finds that all the three angles of the triangle measure 60° each.

Now he draws a triangle all of whose sides are 10 cm each. Which of these is true about the three angles of this triangle?

- A.** All the three angles will measure 30° each **B.** All the three angles will measure 60° each
C. All the three angles will measure 120° each **D.** We cannot say anything without measuring the angles

-
- 15** Three equilateral triangles are inscribed in a circle with center O as shown below.

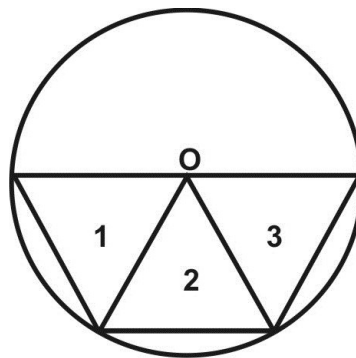

Which of the three triangles are congruent?

- A.** Triangles 1 and 2 only **B.** Triangles 2 and 3 only
C. Triangles 1 and 3 only **D.** All the three triangles

This redacted item is not for public release

17 The subtraction of $\overrightarrow{OM} - \overrightarrow{ON}$ is:

A. \overrightarrow{NM}

B. \overrightarrow{MN}

C. $|\overrightarrow{MN}|$

D. MN

18 Of the pieces shown here, which two could form a semicircle when placed next to each other with their edges touching?

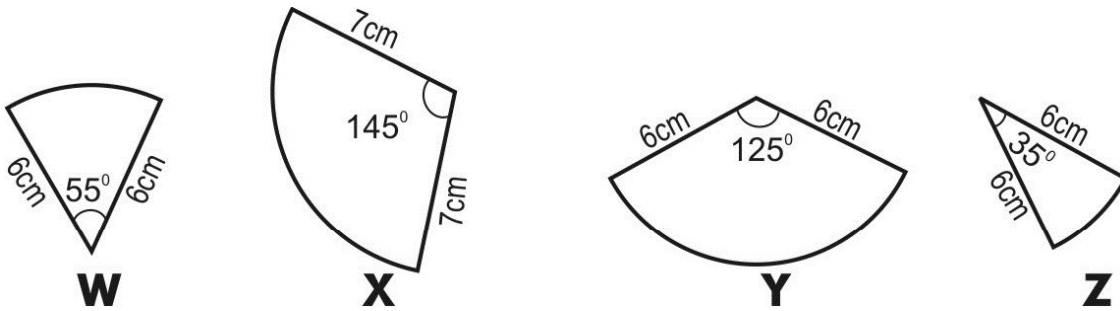

A. Z and W

B. W and Y

C. Y and Z

D. Z and X

19 Line (d) passes point $A(4;5)$ with the perpendicular vector $\vec{n} = (2;1)$. The parametric equation of (d) is:

A. $\begin{cases} x = 4 + 2t \\ y = 5 + t \end{cases}$

B. $\begin{cases} x = 2 + 4t \\ y = 1 + 5t \end{cases}$

C. $\begin{cases} x = 4 + t \\ y = 5 - 2t \end{cases}$

D. $\begin{cases} x = 2 + 5t \\ y = 1 - 4t \end{cases}$

20 Given is a circle (C) with the center $I(3;-4)$, the radius $R = 5$. The equation of circle (C) is:

A. $(x+3)^2 + (y-4)^2 = 5$

B. $(x-3)^2 + (y+4)^2 = 5$

C. $(x+3)^2 + (y-4)^2 = 25$

D. $(x-3)^2 + (y+4)^2 = 25$

21 Given are 3 random points M, N, P . Which following answer equals to \overrightarrow{MN} ?

A. $\overrightarrow{MP} + \overrightarrow{NP}$

B. $\overrightarrow{PN} - \overrightarrow{PM}$

C. $\overrightarrow{MP} - \overrightarrow{PN}$

D. $\overrightarrow{PM} - \overrightarrow{PN}$

22 The given statement " $\forall \in R, x^2 - 2x + 4 > 0$ ". Which statement is the negative clause of the mentioned clause?

A. " $\forall \in R, x^2 - 2x + 4 \leq 0$ "

B. " $\exists \in R, x^2 - 2x + 4 \leq 0$ "

C. " $\exists \in R, x^2 - 2x + 4 > 0$ "

D. " $\exists \in R, x^2 - 2x + 4 < 0$ "

23 In a vase, there are 6 times as many roses as lilies.

If R stands for the number of roses and L stands for the number of lilies, which of the following equations describes the above statement?

A. $R = 6L$

B. $6R = L$

C. $R = L + 6$

D. $6R = 6L$

This redacted item is not for public release

25 Which following point belongs to the line representing $y = -3x + 1$?

A. (1; 0)

B. (-2; 5)

C. (-2; -5)

D. (-2; 7)

26 Which of the following polynomials has a factor $(m + n)$?

A. $m^2 + n^2$

B. $(m - n)^2$

C. $m^2 + mn + n^2$

D. $-km - kn - (m + n)$

This redacted item is not for public release

28

For any numbers x and y such that $x = 70 + y$, what can be said about x and y ?

A. $x = y$

B. $x < y$

C. $x > y$

D. None of the above can be said as the exact values of x or y are NOT known**29**

$y + 10 < 10$. Which of these is DEFINITELY true?

A. y is any negative number.**B.** y is a positive number less than 10.**C.** y has to be a negative number less than -10.**D.** $y + 10$ cannot be less than 10 for any value of y .**30**

What are the coordinates of I of parabola (P): $y = -x^2 - 2x + 5$?

A. $I(-2; 5)$

B. $I(-1; 6)$

C. $I(1; 2)$

D. $I(2; -3)$

31

The line representing $y = 3x + 2$ will intersect with the line representing which equation?

A. $y = 3x$

B. $y = -3x + 4$

C. $y = 3x + 5$

D. $y = 3x - 1$

32

The set of the roots of in equation $x^2 - x - 6 < 0$ is:

A. $(-\infty; -3) \cup (2; +\infty)$

B. $(-3; 2)$

C. $(-2; 3)$

D. $(-\infty; -2) \cup (3; +\infty)$

33

Equation $x^2 - 2x + m - 1 = 0$ has roots when and only when:

A. $m \geq 2$

B. $m > 2$

C. $m < 2$

D. $m \leq 2$

35 A group of 10 friends have some marbles with them. If they had 3 more marbles, they would be able to distribute the marbles equally amongst themselves. Which of these could be the number of marbles they had?

A. 13

B. 20

C. 33

D. 47

36 Tú's father is 6 times as old as Tú. Tú's mother is 25 years old. The average age of this family of three is 20 years. How old is Tú?

A. 15 years

B. 10 years

C. 7 years

D. 5 years

37 A sheet of paper is 0.012 cm thick. Of the following, which would be the height of a stack of 400 sheets of this paper?

A. 0.048 cm

B. 0.48 cm

C. 4.8 cm

D. 48 cm

38

Observe the number pattern in the number triangle below.

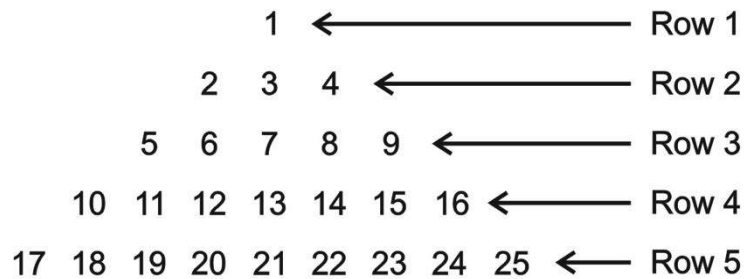

If it is extended, what will be the last number (on the right) in the 9th row?

- | | |
|--------------|--------------|
| A. 25 | B. 36 |
| C. 61 | D. 81 |

39

A field PQRS is in the shape of a quadrilateral.

If you walked from Q to P to S to R along the boundary of the field, you would have covered 140 metres. If you walked from P to S to R to Q along the boundary of the field, you would have covered 135 metres.

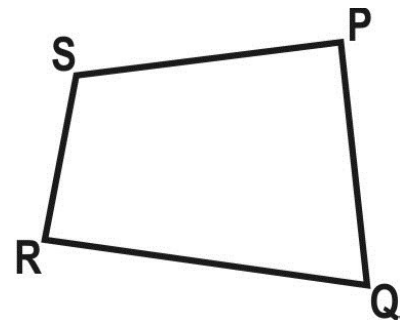

Based on this, which of the following can you conclude?

- | | |
|------------------------------------|---|
| A. PQ is 5 m longer than QR | B. QR is 5 m longer than SR |
| C. PS is 5 m longer than PQ | D. The perimeter of the field is 275 m |

40

80 girls and 100 boys appeared for the class 10 board exam from Phù Đổng School. 25% of the girls and 10% of the boys who appeared got A grades.

What percentage of the total number of students who appeared got A grades?

- | | |
|------------------|------------------|
| A. 16.70% | B. 17.50% |
| C. 25% | D. 35% |